

SAM 400

VERTICAL

HIGH-DENSITY BALER FOR LARGE VOLUMES

SAM 400 is a high-density baler with a generous infeed for compacting large volumes of material and it produces large, dense and uniform bales. It is equipped with a sliding door that opens automatically after each press cycle.

SAM 400 features unique touchscreen controls for ease of use and deal effectively with large volumes of recyclables.



Sliding door



400 KG
BALE WEIGHT (UP TO)
CARDBOARD

Expertise through experience

SACRIA is a market leading manufacturer of high quality compaction equipment. Based on more than 40 years of experience and over 35 000 machines delivered worldwide. Partner up with us. We are there for you all the way!



Benefits for you

- + Save time and increase productivity!
- + Gain valuable floor space!
- + Optimize logistics! Reduce transportation costs!
- + Safe and comfortable working environment
- + More profitable waste management and increased income from sales of recyclables

SAM 400

High-density baler

OPTIMIZED FOR:

PAPER

+ Cardboard

PLASTIC

+ Shrink film

VERSATILE AND RESILIENT BALER

Our tough and robust high-density baler for big volumes of material has a strong construction, a long service life and many application areas.

SEMI-AUTOMATIC SLIDING DOOR & BALING

SAM 400 is equipped with a semi-automatic sliding door, that opens automatically when the compaction cycle is completed, which saves time and facilitates the work. The manual bale binding by strap or wire is a simple procedure and the when pushing the buttons on the side of the machine, the baler automatically ejects the bale.

OPTIMIZE LOGISTICS

SAM 400 produces large, compact and uniform bales. The bale fits a standard pallet of 1200 x 1200 x 850 mm perfectly, making it ideal for storage, internal and external logistics.

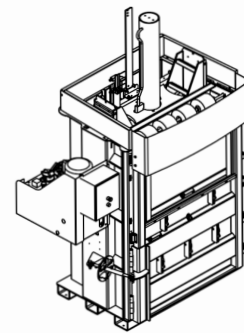

DIMENSIONS & SPECIFICATIONS

DIMENSIONS

A	B*	C	D
1165 mm	2065 mm	1195 mm	3050 mm

*Transport height

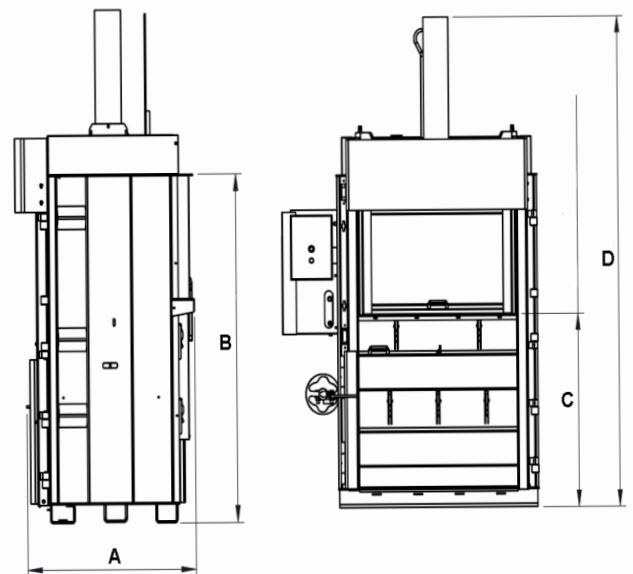

TECHNICAL SPECIFICATIONS

LOADING APERTURE	CYCLE TIME	PRESS FORCE	BALE SIZE	BALE WEIGHT	RAM SURFACE	MOTOR	MACHINE WEIGHT
Width: 1090 mm Height: 540 mm	40 secs	52 ton, 520 kN	HxWxD: 1200 x 1200 x 850 mm	Cardboard: up to 400 kg	1200 x 850 mm	7.5 kW 3- phase	1600 kg
					SURFACE PRESSURE 5.1 kg/cm ²		

We reserve the right to make changes to specifications without prior notice. Bale weights are dependent upon material type.