



OPTIMUM 8

Best driving and lifting experience

- AC powered
- High precision driving
- Proportional and quick movements
- Best turning radius

Utmost versatility

- Ability to go through standard doorways
- Mobile potholes protection
- Indoor - Outdoor rated

Minimal maintenance and downtime

- Maintenance free AC motors
- Easy access
2 swing out trays
- Haulotte ACTIV'Screen (onboard diagnostic)
- Smart transportability

Longer life time

- Extreme robustness
- Optimized total cost of ownership
- Upgraded residual value





OPTIMUM 8

ELECTRIC SCISSOR LIFTS

TECHNICAL DATA

Optimum 8

Working height	7.77 m
Platform height	5.77 m
Driveable at full height up to	5.77 m
Lift capacity - inside	230 kg
Lift capacity - outside	230 kg
A Platform length - outside	1.73 m
B Platform length - extended	2.59 m
Length - extension	0.86 m
C Platform width - outside	0.74 m
D Height - stowed	1.99 m
E Overall width	0.79 m
F Length	1.9 m
G Wheelbase	1.38 m
H Ground clearance - Center	8.7 cm
Ground clearance - Pothole guards deployed	2 cm
Drive speed	0.5 - 5.0 km/h
Gradeability	25 %
Tilt	1.5° - 3°
Lift / lower speed	20 s / 18 s
Turning radius - outside	1.5 m
Non-marking tires	12.5 x 4.13
Batteries	24 V - 105 Amph (C5)
Hydraulic system capacity	6 l
Weight	1 530 kg

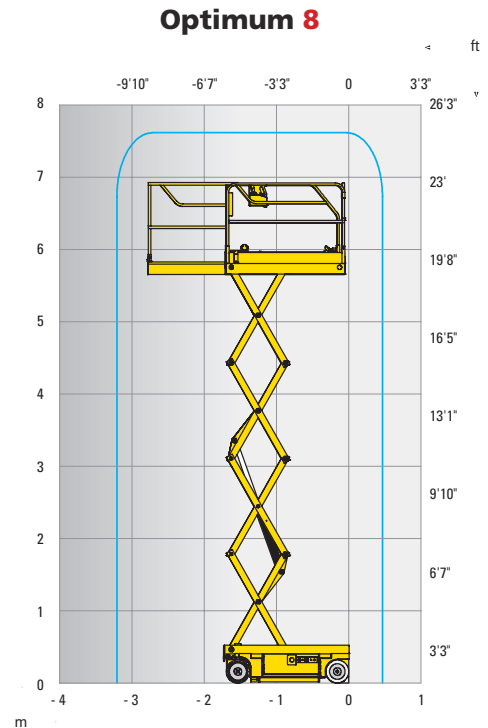

STANDARD EQUIPMENT

- 24 V electric drive Brushless AC motors
- 24 V - 105 Ah C5 batteries
- Battery charge indicator
- Battery level indicator on upper and lower control boxes
- Haulotte Activ'Screen (battery charge, Hourmeter, service alert & failures icons in code or in full text...)
- 2 swing out trays
- Lateral fork lifting pockets
- Electric or manual break release system
- lifting and stowage points
- Non marking tires

OPTIONS AND ACCESSORIES

- Maintenance free gel batteries
- Pipe cradle
- Swing door entry gate
- Flashing light
- Dual flashing lights
- Working light
- AC power to platform
- Additional battery cut-off
- Hydraulic oil for cold countries

