



Precision and flexibility

- Proportional control of movements
- Hydrostatic transmission and inching pedal

Compact and versatile

- 5 m length
- Short turning radius
- Driving position reduces fatigue at work

Comfort and ergonomomy

- LMI easy to read with cut off dangerous movements
- Tilt corrector as standard
- Tilt corrector as standard
- Smart control 4 in 1 joystick



Placing height : 10 m



Maximum lift capacity :
3500 kg

Haulotte 
GROUP

More than lifting



Placing height : 10 m
Maximum lift capacity : 3500 kg



PERFORMANCES

Maximum lift capacity	3500 kg
Lift capacity to full height	2000 kg
Lift capacity at full reach	500 kg
Maximum fork height	10 m
Reach at maximum fork height	2.2 m
Maximum forward reach	7.2 m



DIMENSIONS

A Length	4.96 m
B Width	2.26 m
C Height	2.42 m
D Wheelbase	2.78 m
E Ground clearance	42 cm
F Track width	1.88 m
G Cab width	0.96 m
H Height to high boom pivot	1.6 m
J Approach angle	30°
K Upper rotation of forks	18°
L Lower rotation of forks	104°
Turning radius (outside wheels)	3.7 m
Weight with forks	8280 kg
Tyres type	405/70 - 24



ENGINE

	TIER III	TIER IV
Engine model	PERKINS	KOHLER
Engine Capacity	4400 cm ³	3400 cm ³
Engine power output	70 kW	55,4 kW
Engine torque	392 Nm	380 Nm
Transmission type	Hydrostatic	Hydrostatic
Fuel tank	120 l	120 l
Engine oil	7 l	15 l

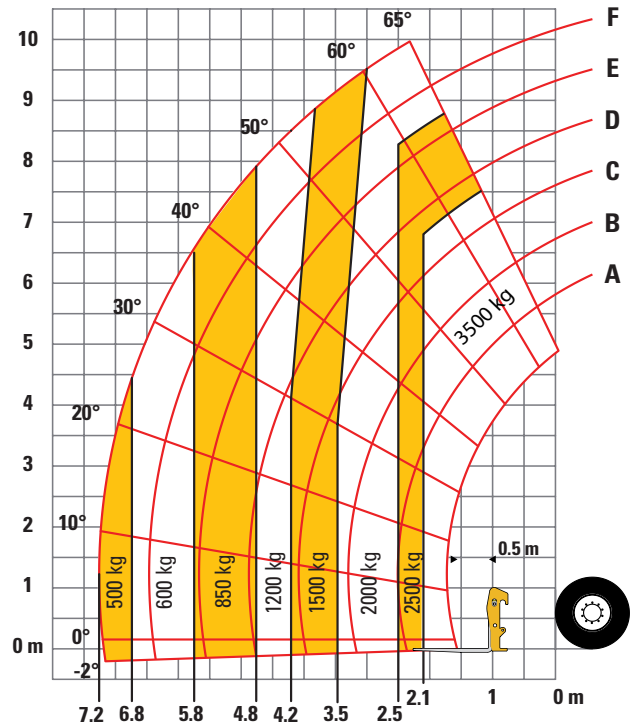
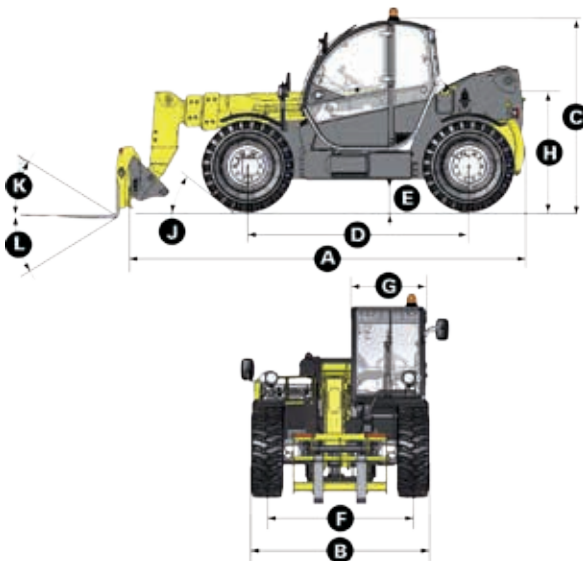

STANDARD EQUIPMENT

- Heavy duty Hydrostatic transmission
- 4 wheel drive and steer
- Gear equipment pump
- Proportional controls for movement of boom/telescopic arm/excavation and accessories
- Safety valves on hydraulic jacks
- Auxilliary hydraulic ports
- Overload/dangerous movements cut out switch
- Tilt corrector: +/- 10°
- ROPS/FOPS cabin with heating and ventilation
- Backlighted e-tronic dashboard

OPTIONS AND ACCESSORIES

- Cold Weather Package
- Biodegradable oil
- Cold environment oil
- Hot environment oil
- Air conditioning
- Working lights
- Buckets
- Jibs
- Electrically hydraulic controls

